



Eurocheck
CS 2099
User manual

Version 1.3.6, Code no. 20 750 127



METREL®

Distributor:

Manufacturer:

Metrel d.d.
Ljubljanska cesta 77
SI-1354 Horjul
Slovenia
<https://www.metrel.si>
info@metrel.si



Mark on your equipment certifies that it meets requirements of all subjected EU regulations.



Hereby, Metrel d.d. declares that the CS 2099 is in compliance with subjected EU directive. The full text of the EU declaration of conformity is available at the following internet address <https://www.metrel.si/DoC>.

© 2022 METREL

The trade names Metrel[®], Smartec[®], Eurotest[®], Auto Sequence[®] are trademarks registered in Europe and other countries.

No part of this publication may be reproduced or utilized in any form or by any means without permission in writing from METREL.

1	Introduction to CS 2099 – Eurocheck.....	4
2	Safety and operational considerations	5
2.1	Warnings	5
2.2	Standards applied	5
3	Eurocheck description and maintenance	6
3.1	Front panel	6
3.2	Side panel	7
3.3	Replacing fuse.....	8
3.4	Cleaning	8
3.5	Periodic calibration	8
3.6	Service	8
4	Eurocheck operation.....	9
4.1	Recommended calibration sequence and practice	9
4.2	Sample test report form	10
4.3	Selecting calibration function/sub-function	11
4.4	Selecting appropriate test cable for calibration.....	11
4.5	Fault loop impedance calibration.....	12
4.6	Trip-lock impedance calibration.....	14
4.7	Line impedance calibration.....	15
4.8	RCD trip-out time calibration	16
4.9	RCD measuring current $I_{\Delta n}=30$ mA verification	17
4.10	Insulation resistance calibration	17
4.11	Low Ω and continuity resistance calibration	18
4.12	Voltage and frequency calibration	20
4.13	Continuity and insulation of measurement leads verification	21
4.14	PE test terminal operation verification	22
5	Technical specifications	23
5.1	General	23
5.2	Calibration references	23

1 Introduction to CS 2099 – Eurocheck

CS 2099 – Eurocheck is a professional, multifunctional field calibrator intended for use with Metrel installation test instruments. In addition to its durable body and simple operation it boasts the following features:

- ❑ Insulation calibration with test voltages up to 1000 V,
- ❑ Low Ω and continuity function calibration,
- ❑ Continuity and insulation of measurement leads verification,
- ❑ Fault loop and trip-lock impedance calibration (all test currents supported on Metrel instruments),
- ❑ Calibration of RCD trip-out time measurement, including test current verification (30 mA test current is supported),
- ❑ Line impedance calibration,
- ❑ Voltage and frequency calibration,
- ❑ PE test terminal functional verification.

Functioning and accuracy of all Metrel and most other manufacturer's installation test instruments can be verified with Eurocheck. However, not all instruments support all functions available on Eurocheck. Refer to your instrument User manual for a complete list of its measuring functions. The instrument list includes (but is not limited to):

- ❑ MI3100 – EurotestEASI,
- ❑ MI3101 – EurotestAT,
- ❑ MI3102 – EurotestXE,
- ❑ MI2086 – Eurotest,
- ❑ MI2087 – Instaltest,
- ❑ MI2087AL2 – Easitest,
- ❑ Smartec family of instruments.

Installation test instruments are usually used on a daily basis in harsh environment conditions. Often the user doesn't have confidence in instrument operation and its accuracy. Continuity of measurement leads presents additional problem. Many times it is not possible to conclude the instrument state from ordinary measurement results. Such results may look correct, but in fact they are wrong due to the instrument malfunctioning. Regular test instrument calibration with Eurocheck will reveal such problems.

Eurocheck doesn't provide a complete calibration solution for installation test instruments. Regular 6-months or 1-year calibration of all measurement functions of the instrument is still recommended. What it does provide is simple field calibration of the most frequently used functions when testing installations. Furthermore, in some countries it is obligatory for approved contractors to demonstrate trustworthy control system for ensuring accuracy of test instruments (like NICEIC in United Kingdom). Eurocheck represents one simple solution in such cases.

Notes:

- ❑ If in doubt about instrument operation and/or its accuracy, send it to your distributor or manufacturer for a complete calibration and service, if required. The same is valid if you're in doubt about Eurocheck operation.
- ❑ Installation measurements in general and typical applications are explained in Metrel handbook *Measurements on electric installations in theory and practice*.

2 Safety and operational considerations

2.1 Warnings



Read and understand all warnings and cautions before using this product. This will ensure your safety, as well as keep the test equipment undamaged.

- ❑  **symbol on the instrument means »Read the Instruction manual with special care«. The symbol requires an action!**
- ❑ If the test equipment is used in a manner not specified in this user manual the protection provided by the equipment may be impaired!
- ❑ Read this user manual carefully, otherwise use of the instrument may be dangerous for the operator, for the instrument or for the equipment under test!
- ❑ Do not use the test equipment and accessories if any damage is noticed!
- ❑ In case a fuse has blown follow the instructions in this manual to replace it!
- ❑ Consider all generally known precautions in order to avoid risk of electric shock while dealing with hazardous voltages!
- ❑ Do not use the test equipment in supply systems with voltages higher than 230 V!
- ❑ Do not disassemble, risk of electric shock – service intervention or adjustment procedure is allowed to be carried out only by a competent authorized person!
- ❑ Use only standard or optional test accessories supplied by your distributor!
- ❑ Do not short-circuit any of the calibrator inputs/outputs!

Immediately disconnect from the power line and discontinue use if:

- ❑ the calibrator is dropped or subjected to an impact in which the interior is exposed,
- ❑ the calibrator emits a strange smell, excessive heat, or smoke.

Function specific warnings (applies to all operations performed with Eurocheck):

- ❑  In some countries the type of mains plug determines L and N wiring positions. If Eurocheck signals incorrect polarity this represents an installation fault, which should be corrected immediately.
- ❑  When performing fault loop/trip-lock/line impedance calibration Eurocheck always connects loop calibration output to mains line impedance (L and N), thus avoiding tripping an RCD on mains supply. When evaluating absolute measurement results line impedance of the mains has to be considered, not fault loop impedance. Recommended calibration procedure, described in this document, relies on the absolute result and the difference between two measured values.

2.2 Standards applied

The CS 2099 - Eurocheck calibrator is manufactured and tested in accordance with the following regulations:

- ❑ Safety regulations EN 61010-1
- ❑ Electromagnetic compatibility regulations EN 61326

3 Eurocheck description and maintenance

3.1 Front panel

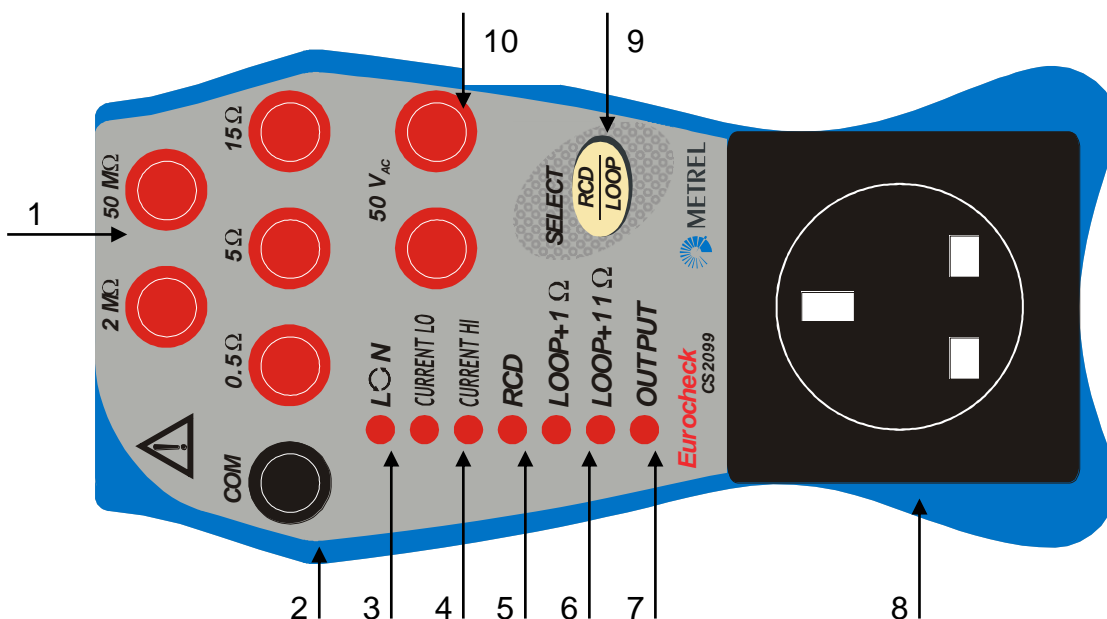

Figure 3.1: Front panel

Note:
Output connector type is country dependent.

Legend:

- 1..... Insulation calibration outputs.
- 2..... Low Ω and continuity calibration outputs.
 ⚠ Caution – do not use test currents higher than 200 mA.
- 3..... Power supply cord connection polarity indication.
 ⚠ LED lights if L and N lines are incorrectly connected – reverse connection.
- 4..... Incorrect test current indication for RCD trip-out time function verification (appropriate LED lights if test current is too low or too high).
- 5..... RCD test calibration function selected.
- 6..... Fault loop calibration function selected (each LED indicates sub-function), also used for trip-lock/line impedance calibration.
- 7..... LED lights if voltage is present at RCD/Fault loop calibration output.
 Press RCD/LOOP selection button (9) once after connecting the calibrator to the power supply to enable voltage at output connector.
 LED goes out whenever RCD simulator trips and is automatically restored 3 seconds afterwards (other LEDs remain lit during this period).
- 8..... RCD/Fault loop calibration output (used for fault loop/trip-lock/line impedance and RCD trip-out time calibration).
 ⚠ Caution – line voltage present on test terminals!
 ⚠ Consider specified duty cycle when calibrating fault loop or line impedance to avoid overheating of Eurocheck.
- 9..... RCD/Fault loop selection button.
 Press repeatedly to cycle through available options: enable output, LOOP+11 Ω, LOOP+1 Ω, RCD, disable output.
- 10..... Voltage/frequency calibration output.

3.2 Side panel

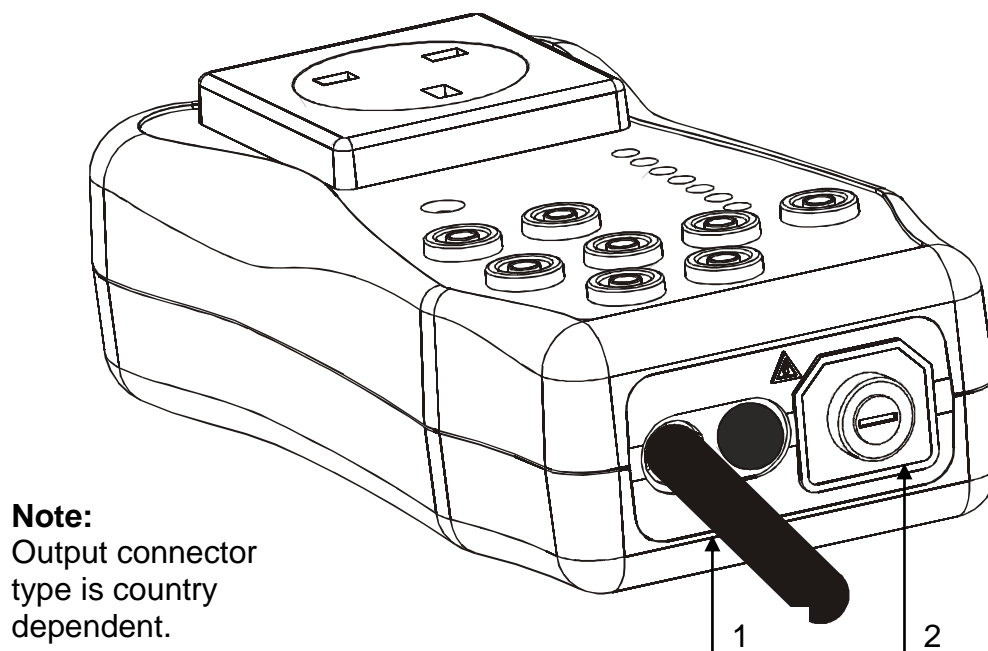

Figure 3.2: Side panel

Legend:

- 1..... Power supply cord.
- 2..... Fuse F1.

Note:

Eurocheck powers on automatically 2 seconds after it is connected to the mains supply. It checks for correct mains supply plug orientation during power up. If the orientation is wrong "incorrect polarity" LED lights. In such case reverse connection of power supply cord.

3.3 Replacing fuse

A fuse is located under side cover of the Eurocheck unit:

- F1
T 4 A / 230 V, 32 mm × 6.3 mm
General input protection fuse.

Warnings:

-  Disconnect any connected instrument/accessory and power off the calibrator before opening fuse compartment cover, hazardous voltage inside!
- Replace blown fuse with original type only, otherwise the calibrator may be damaged and/or operator's safety impaired!

Position of the fuse can be seen in Figure 3.2 in chapter 3.2.

3.4 Cleaning

No special maintenance is required for the housing. To clean the surface of the instrument use a soft cloth slightly moistened with soapy water or alcohol. Then leave the instrument to dry totally before use.

Warnings:

- Do not use liquids based on petrol or hydrocarbons!
- Do not spill cleaning liquid over the instrument!

3.5 Periodic calibration

It is essential that the unit is regularly calibrated in order technical specification listed in this manual is guaranteed. We recommend an annual calibration. An authorised technical person should do the calibration. Please contact your dealer or manufacturer for further information.

3.6 Service

For repairs under warranty, or at any other time, please contact your distributor.

Unauthorised person is not allowed to open the Eurocheck calibrator. There are no user replaceable components inside the instrument, except one fuse, refer to chapter 3.3.

4 Eurocheck operation

4.1 Recommended calibration sequence and practice

This chapter lists recommended sequence for calibration of installation test instruments. It is not obligatory to follow this sequence. Eurocheck offers additional calibration functions (all functions are explained in detail in the following chapters).

Calibration using universal test cable

<i>Step</i>	<i>Calibrated function</i>	<i>Purpose</i>
1	Low Ω	Determination of measurement accuracy. Verification of universal test cable wire continuity (incomplete).
2	Continuity	Determination of measurement accuracy.
3	Insulation	Determination of measurement accuracy. Verification of universal test cable wiring insulation resistance (incomplete).
4	Voltage	Determination of measurement accuracy. Verification of universal test cable or tip commander wiring continuity and insulation state (complete in most cases, refer to chapter 4.13).

Calibration using plug cable

<i>Step</i>	<i>Calibrated function</i>	<i>Purpose</i>
5	Fault loop impedance and/or Trip-lock impedance	Determination of measurement accuracy. Verification of plug cable wiring continuity (incomplete).
6	RCD trip-out time	Determination of measurement accuracy.

For further information on how to perform each measurement with your instrument see its User manual.

Notes:

- It is advisable to perform at least 3 consecutive measurements to verify stability of measurement results. Consider accuracy of calibrated function when evaluating calibration results. Accuracy of each function is defined in User manual of your instrument.
- If calibration results deviate significantly from reference values, it is very likely the tested instrument is damaged. Send it to your distributor or manufacturer for repair and/or readjustment.
- It is a good practice to file results after each calibration. Variation of results over time period may indicate malfunctioning of the instrument.
- It is best to perform calibrations in similar environment conditions, since changes of temperature and relative humidity influence test instrument operation and Eurocheck reference values. In any case note environmental conditions of calibration when storing measurement results.

4.2 Sample test report form

Caution:

- This sample test report form is suitable for Metrel installation test instruments like MI3100 – EurotestEASI. It could be easily modified to suit other types of instruments.
- It is not based on any regulation or recommendation.

Type of calibrated instrument

SN of calibrated instrument

Date of calibration

Temperature (°C)

Relative humidity (%RH)

Function	Eurocheck value	Measured value
Low Ω (± 200 mA)	0.5 Ω	Ω
	5 Ω	Ω
	15 Ω	Ω
Continuity (7 mA)	0.5 Ω	Ω
	5 Ω	Ω
	15 Ω	Ω
Insulation 100 V	2 M Ω	M Ω
	50 M Ω	M Ω
Insulation 250 V	2 M Ω	M Ω
	50 M Ω	M Ω
Insulation 500 V	2 M Ω	M Ω
	50 M Ω	M Ω
Insulation 1000 V	2 M Ω	M Ω
	50 M Ω	M Ω
Voltage, frequency	U _{L-N} , 50 V	V
	U _{L-PE} , 50 V	V
	U _{N-PE} , 50 V	V
	50 Hz	Hz
Fault loop impedance	LOOP+1 Ω	Ω
	LOOP+11 Ω	Ω
Trip-lock impedance I Δ n=30 mA	LOOP+1 Ω	Ω
	LOOP+11 Ω	Ω
RCD trip-out time I Δ n=30 mA	50 ms	ms
	CURRENT LO	PASS / FAIL
	CURRENT HI	PASS / FAIL

Reference equipment **SN** **Calibration certificate no.** **Date of calibration**

Metrel Eurocheck

Operator's name and signature

4.3 Selecting calibration function/sub-function

The following measurements can be selected with the RCD/LOOP function selection button (see Figure 3.1). Appropriate LED lights when particular function/sub-function is selected:

- Fault loop and trip-lock impedance calibration (two impedance values available),
- RCD trip-out time calibration and instrument test current verification.

The following measurements are not indicated with LEDs on front panel. Connect the tested instrument to the outputs particular to each function:

- Insulation resistance,
- Low Ω and continuity resistance,
- Voltage and frequency calibration,
- Line impedance calibration,
- Continuity and insulation of measurement leads verification,
- PE test terminal operation verification.

Note:

- For descriptions of instrument measurement functions refer to its User manual.

4.4 Selecting appropriate test cable for calibration

Functions that use Eurocheck RCD/Fault loop calibration output can be calibrated using universal test cable, plug cable or plug commander. Use test tips to connect universal test cable into Eurocheck RCD/Fault loop calibration output:

- Fault loop impedance,
- Trip-lock impedance,
- RCD trip-out time and instrument test current $I_{\Delta n}$,
- Line impedance,
- PE test terminal operation verification.

Measurement results should be the same, regardless of selected cable.

It is possible that the cause for incorrect calibration result is broken wire or deteriorated insulation in measurement cable. Correctness of universal test cable wiring can be easily verified, see chapter 4.13. If this cable passes verification, use it to perform calibration of functions listed above. Write down measurement results. Then use other type of cable and repeat calibration. Compare measurement results, they should be close to each other.

Other functions can be calibrated with universal test cable and tip commander:

- Insulation resistance,
- Low Ω and continuity resistance,
- Voltage and frequency,
- Continuity and insulation of measurement leads verification.

For further information on how to use each cable type see User manual of your instrument.

4.5 Fault loop impedance calibration

Fault loop impedance is measured between L and PE conductors. Fault loop calibration will not trip an RCD if it's present in installation where Eurocheck is connected, regardless of selected I Δ n current.

Caution:

- ❑  When performing fault loop impedance calibration Eurocheck connects fault loop calibration output to mains line impedance (L and N, important when evaluating calibration measurement results).
- ❑ When evaluating absolute measured values first perform *line impedance* measurement of the wall socket to which Eurocheck is then connected. Consider that the impedance of Eurocheck mains cable is added to this value.

Fault loop impedance calibration can be performed with universal test cable, plug cable or even plug commander.

Step	Action
1	<ul style="list-style-type: none"> ❑ Connect the tested instrument into Eurocheck RCD/Fault loop output using one of available cables (plug cable, plug commander, universal test cable); follow connection diagrams shown in Figure 4.1 and Figure 4.2.
2	<ul style="list-style-type: none"> ❑ Switch on the tested instrument and select fault loop impedance function.
3	<ul style="list-style-type: none"> ❑ Connect Eurocheck into mains wall socket and enable its output. ❑ Observe any warnings displayed on the tested instrument and Eurocheck. ❑ If Eurocheck signals incorrect L and N polarity, reverse connection.
4	<ul style="list-style-type: none"> ❑ Select LOOP+11 Ω function on Eurocheck using RCD/LOOP button, LOOP+11 Ω LED lights. ❑ Observe any warnings displayed on the tested instrument and Eurocheck. If any is present, remove the causes before proceeding.
5	<ul style="list-style-type: none"> ❑ Perform fault loop impedance measurement with the tested instrument. ❑ Write down measurement result for documentation purposes (it will be in 11 Ω – 12 Ω range in most cases).
6	<ul style="list-style-type: none"> ❑ Select LOOP+1 Ω function on Eurocheck, LOOP+1 Ω LED lights. ❑ Observe any warnings displayed on the tested instrument and Eurocheck. If any is present, remove the causes before proceeding.
7	<ul style="list-style-type: none"> ❑ Perform fault loop impedance measurement with the tested instrument. ❑ Write down measurement result for documentation purposes (it will be in 1 Ω – 2 Ω range in most cases).
8	<ul style="list-style-type: none"> ❑ Calculate the difference between LOOP+11 Ω and LOOP+1 Ω measurement results – it has to be close to 9.8 Ω (see Eurocheck technical specification). ❑ If impedance difference deviates significantly from 9.8 Ω, it is very likely the tested instrument is damaged. Send it to your distributor or manufacturer for repair and/or readjustment.
9	<ul style="list-style-type: none"> ❑ Repeat steps 4 – 8 with reverse polarity of test current in fault loop impedance function (if the tested instrument enables reverse polarity selection).

Note:

- In some instruments the function is named “Fault loop resistance”; however the calibration procedure is the same.

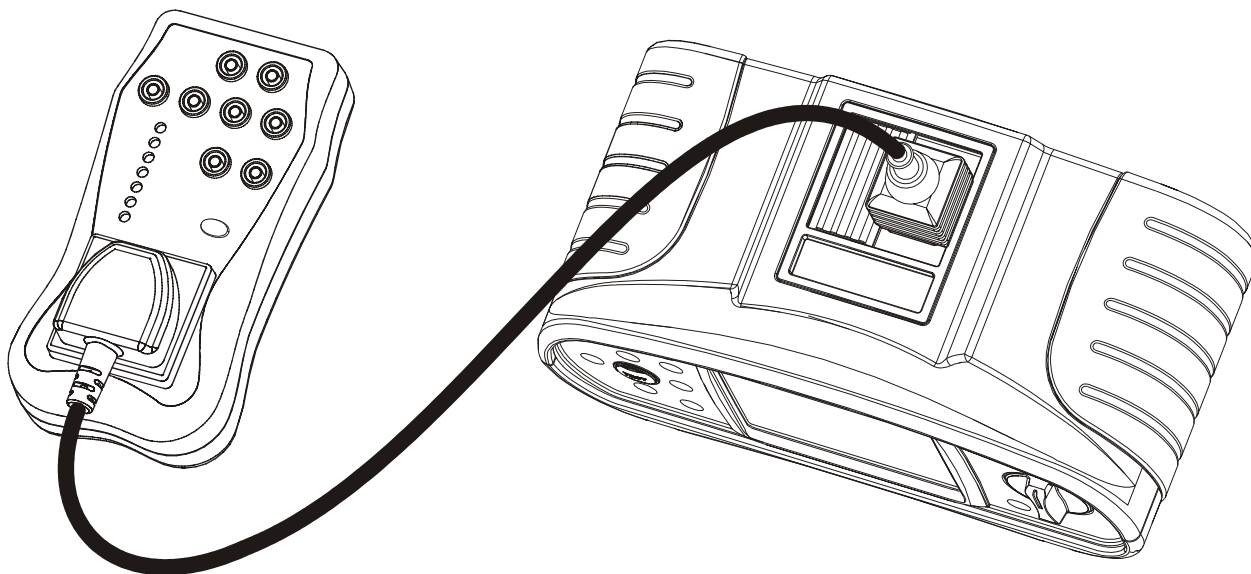

Figure 4.1: Performing fault loop impedance calibration using plug cable

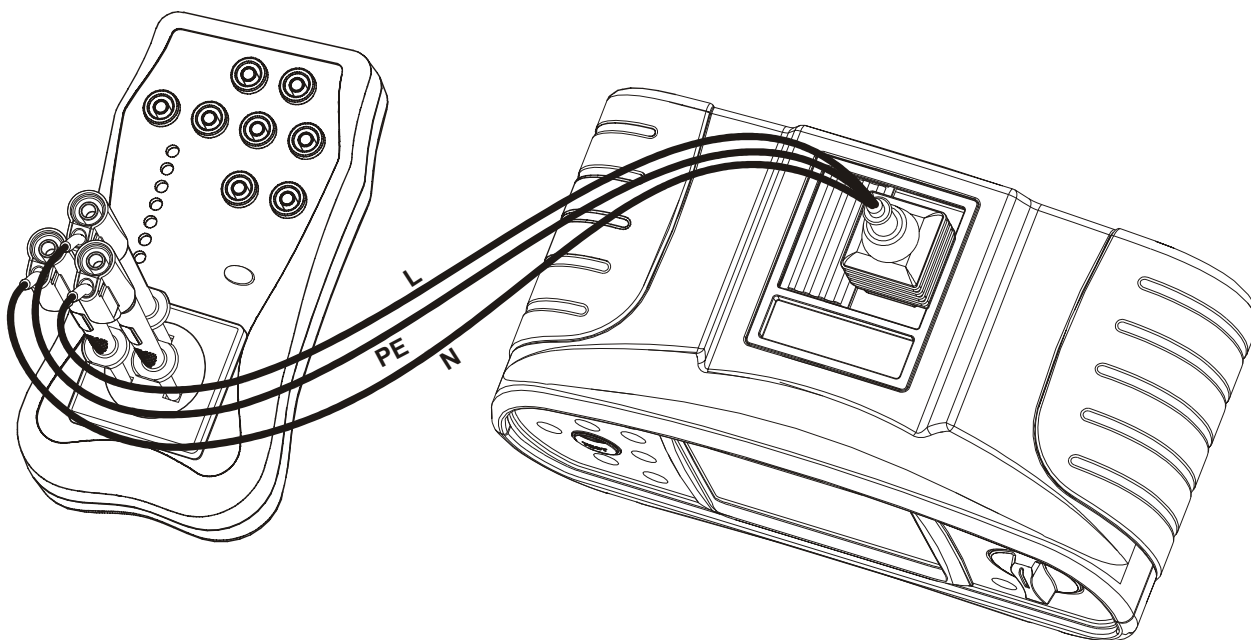



Figure 4.2: Performing fault loop impedance calibration using universal test cable

4.6 Trip-lock impedance calibration

Fault loop impedance is measured between L and PE conductors. Trip-lock calibration will not trip an RCD if it's present in installation where Eurocheck is connected, regardless of selected $I_{\Delta n}$ current.

Caution:

- ❑  When performing fault loop impedance calibration Eurocheck connects fault loop calibration output to mains line impedance (L and N, important when evaluating calibration measurement results).
- ❑ When evaluating absolute measured values first perform *line impedance* measurement of the wall socket to which Eurocheck is then connected. Consider that the impedance of Eurocheck mains cable is added to this value.

Trip-lock impedance calibration can be performed with universal test cable, plug cable or even plug commander. Calibration can be performed with all $I_{\Delta n}$ currents supported by the tested instrument (even $I_{\Delta n}=10$ mA).

Calibration procedure is basically the same as the procedure for fault loop impedance function (chapter 4.5). Only differences between both procedures are noted below.

Step	Action
1	<ul style="list-style-type: none"> ❑ The same as fault loop impedance function. ❑ Follow connection diagrams shown in Figure 4.1 and Figure 4.2.
2	<ul style="list-style-type: none"> ❑ Switch on the tested instrument and enter trip-lock impedance function. ❑ Select appropriate $I_{\Delta n}$ current. All $I_{\Delta n}$ currents are supported.
3	<ul style="list-style-type: none"> ❑ The same as fault loop impedance function.
4	<ul style="list-style-type: none"> ❑ The same as fault loop impedance function.
5	<ul style="list-style-type: none"> ❑ Perform trip-lock impedance measurement with the tested instrument. ❑ Write down measurement result for documentation purposes (it will be in 11 Ω – 12 Ω range in most cases).
6	<ul style="list-style-type: none"> ❑ The same as fault loop impedance function.
7	<ul style="list-style-type: none"> ❑ Perform trip-lock impedance measurement with the tested instrument. ❑ Write down measurement result for documentation purposes (it will be in 1 Ω – 2 Ω range in most cases).
8	<ul style="list-style-type: none"> ❑ Calculate the difference between LOOP+11 Ω and LOOP+1 Ω measurement results – it has to be close to 9.8 Ω (see Eurocheck technical specification). ❑ If impedance difference deviates significantly from 9.8 Ω, it is very likely the tested instrument is damaged. Send it to your distributor or manufacturer for repair and/or readjustment.
9	<ul style="list-style-type: none"> ❑ Repeat steps 4 – 8 with reverse polarity of test current in trip-lock impedance function (if the tested instrument enables reverse polarity selection).

Notes:

- ❑ In some instruments the function is named “Rs resistance”, “RI resistance” “loop(rcd) or “loop(rcd10mA). The calibration procedure is the same, regardless of the name.

- ❑ Selected I Δ n current will affect dissipation of measurement results. Lower I Δ n currents (especially 10 mA) will cause larger variations in results. Consider accuracy of trip-lock function when evaluating calibration results (accuracy is defined in User manual of your instrument).

4.7 Line impedance calibration

Line impedance is measured between L and N conductors.

Line impedance calibration can be performed with universal test cable, plug cable or even plug commander.

Calibration procedure is basically the same as the procedure for fault loop impedance function (chapter 4.5). Only differences between both procedures are noted below.

<i>Step</i>	<i>Action</i>
1	<ul style="list-style-type: none"> ❑ The same as fault loop impedance function. ❑ Follow connection diagrams shown in Figure 4.1 and Figure 4.2.
2	<ul style="list-style-type: none"> ❑ Switch on the tested instrument and select line impedance function.
3	<ul style="list-style-type: none"> ❑ The same as fault loop impedance function.
4	<ul style="list-style-type: none"> ❑ The same as fault loop impedance function (line impedance will be measured instead of loop).
5	<ul style="list-style-type: none"> ❑ Perform line impedance measurement with the tested instrument. ❑ Write down measurement result for documentation purposes (it will be in 11 Ω – 12 Ω range in most cases).
6	<ul style="list-style-type: none"> ❑ The same as fault loop impedance function (line impedance will be measured instead of loop).
7	<ul style="list-style-type: none"> ❑ Perform line impedance measurement with the tested instrument. ❑ Write down measurement result for documentation purposes (it will be in 1 Ω – 2 Ω range in most cases).
8	<ul style="list-style-type: none"> ❑ Calculate the difference between LOOP+11 Ω and LOOP+1 Ω measurement results – it has to be close to 9.8 Ω (see Eurocheck technical specification). ❑ If impedance difference deviates significantly from 9.8 Ω, it is very likely the tested instrument is damaged. Send it to your distributor or manufacturer for repair and/or readjustment.

4.8 RCD trip-out time calibration

Eurocheck simulates an RCD with $I_{\Delta n}$ of 30 mA and trip-out time of 50 ms. Trip-out time calibration will not trip an RCD if it's present in installation where Eurocheck is connected, regardless of selected $I_{\Delta n}$ current.

Caution:

-  Pay special attention when selecting appropriate $I_{\Delta n}$ current. It should be set to 30 mA, and multiplier should be set to x1. Otherwise the reading of trip-out time may be wrong.

RCD trip-out time calibration can be performed with universal test cable, plug cable or even plug commander.

Step	Action
1	<ul style="list-style-type: none"> □ Connect the tested instrument into Eurocheck RCD/Fault loop output using one of available cables (plug cable, plug commander, universal test cable); follow connection diagrams shown in Figure 4.1 and Figure 4.2.
2	<ul style="list-style-type: none"> □ Switch on the tested instrument and select RCD trip-out time function (usually denoted as RCD t). □ Set $I_{\Delta n}$ to 30 mA and current multiplier to x1.
3	<ul style="list-style-type: none"> □ Connect Eurocheck into mains wall socket and enable its output. □ Observe any warnings displayed on the tested instrument and Eurocheck. □ If Eurocheck signals incorrect L and N polarity, reverse connection.
4	<ul style="list-style-type: none"> □ Select RCD calibration function using RCD/LOOP button (RCD LED lights when the function is selected). □ Observe any warnings displayed on the tested instrument and Eurocheck. If any is present, remove the causes before proceeding.
5	<ul style="list-style-type: none"> □ Perform RCD trip-out time measurement with the tested instrument. □ 30 mA RCD test current is verified simultaneously (chapter 4.9). □ Write down measurement result for documentation purposes.
6	<ul style="list-style-type: none"> □ If measured trip-out time deviates significantly from 50 ms, it is very likely the tested instrument is damaged. Send it to your distributor or manufacturer for repair and/or readjustment.
7	<ul style="list-style-type: none"> □ Repeat steps 5 and 6 with reverse polarity of test current in RCD trip-out time function (if the tested instrument enables reverse polarity selection).

Note:

- Consider accuracy of RCD trip-out time measurement when evaluating calibration results (accuracy is defined in User manual of your instrument).

4.9 RCD measuring current $I_{\Delta n}=30$ mA verification

This test is part of RCD trip-out time calibration and couldn't be performed separately – it is valid only for $I_{\Delta n} = 30$ mA. Refer to chapter 4.8 for more information.

It is essential that the test instrument measuring current is within certain limits. For example, standard EN 61557 defines low limit as $I_{\Delta n} - 0\%$, and high limit as $I_{\Delta n} + 20\%$. Metrel test instruments has even narrower specification, high limit is defined as $I_{\Delta n} + 10\%$.

When RCD trip-out time measurement is performed Eurocheck automatically indicates if test current was too low or too high (LEDs CURRENT LO or CURRENT HI light respectively). Eurocheck low limit indication is set to 28 mA, and high limit to 35 mA.

4.10 Insulation resistance calibration

Eurocheck offers 2 insulation resistance values for calibration: 2 M Ω and 50 M Ω . It is always possible (and recommended) to add third value into your calibration procedure – 0 Ω (short-circuited test leads).

It is necessary to calibrate insulation resistance function with all available measuring voltages. If measuring voltage is set continuously, it is recommended to perform calibration with the following voltages: 50 V, 100 V, 250 V, 500 V and 1000 V.

Fault loop impedance calibration can be performed with universal test cable or tip commander. Make sure to follow connection instructions for the tested instrument (determine the leads of the test cable which are used for this measurement). Generic connection diagram is shown in Figure 4.3.

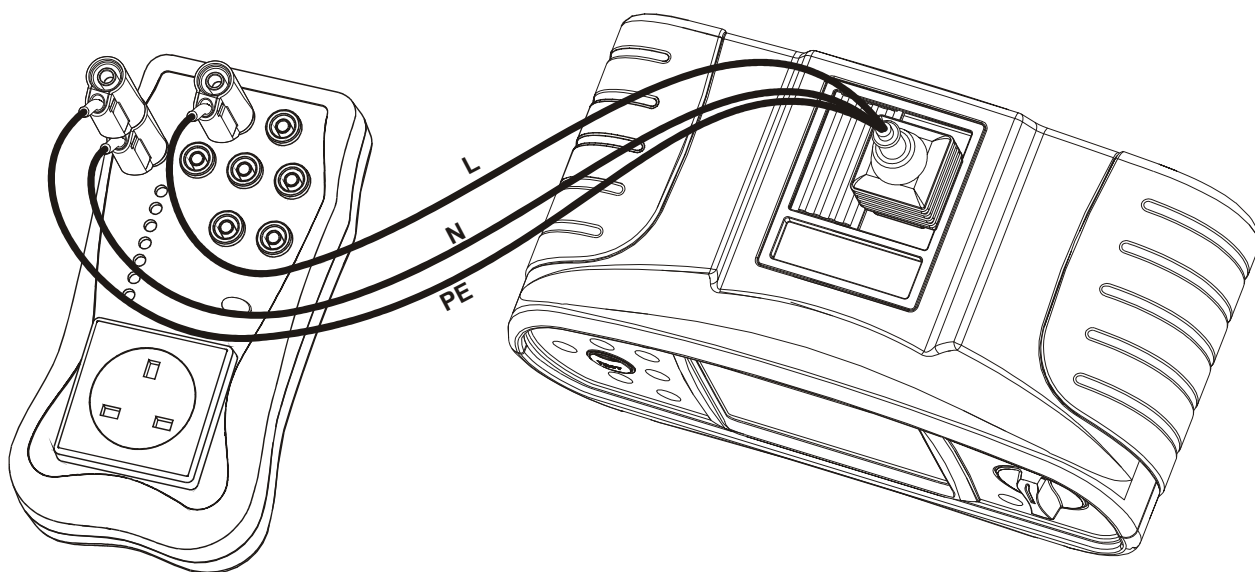

Figure 4.3: Performing insulation resistance calibration using universal test cable

Step	Action
1	<ul style="list-style-type: none"> ❑ Connect tested instrument into Eurocheck insulation resistance test sockets using universal test cable, follow connection diagram shown in Figure 4.3.
2	<ul style="list-style-type: none"> ❑ Switch on the tested instrument and select insulation resistance function. ❑ Set the first measuring voltage.
3	<ul style="list-style-type: none"> ❑ It is not necessary to power on Eurocheck when performing insulation resistance calibration. ❑ Observe any warnings displayed on the tested instrument. If any is present, remove the causes before proceeding.
4	<ul style="list-style-type: none"> ❑ Perform insulation measurement with the tested instrument. ❑ Write down measurement result for documentation purposes.
5	<ul style="list-style-type: none"> ❑ If measured insulation resistance deviates significantly from reference value, it is very likely the tested instrument is damaged. Send it to your distributor or manufacturer for repair and/or readjustment.
6	<ul style="list-style-type: none"> ❑ Repeat steps 4 and 5 with the other reference insulation resistance value.
7	<ul style="list-style-type: none"> ❑ Set another insulation measuring voltage and repeat steps 4 – 6. ❑ Make sure to select all available measuring voltages.

Notes:

- ❑ Some instruments (like MI 3101 – EurotestAT) support measurement of all three insulations in standard mains cable (between L and N, L and PE, N and PE). In such case it is necessary to calibrate each insulation measurement separately.
- ❑ It is advisable to perform at least three consecutive measurements to verify stability of results. If the tested instrument supports continuous insulation measurement it is advisable to test this functionality as well (function is usually engaged by pressing and holding TEST button).

4.11 Low Ω and continuity resistance calibration

Eurocheck offers 3 low resistance values for calibration: 0.5 Ω , 5 Ω and 15 Ω . It is always possible (and recommended) to add fourth value into your calibration procedure – 0 Ω (short-circuited test leads).

Metrel installation test instruments usually offer 2 distinctive functions for measuring low resistances. Low Ω usually stands for measuring low resistances with 200 mA test current, often with automatic polarity reversal. Continuity denotes a function with lower measuring current, usually around 7 mA. Both functions can be calibrated with Eurocheck.

Low resistance measurement calibration can be performed with universal test cable or tip commander. Make sure to follow connection instructions for the tested instrument (determine the leads of the test cable which are used for this measurement). Generic connection diagram is shown in Figure 4.4.

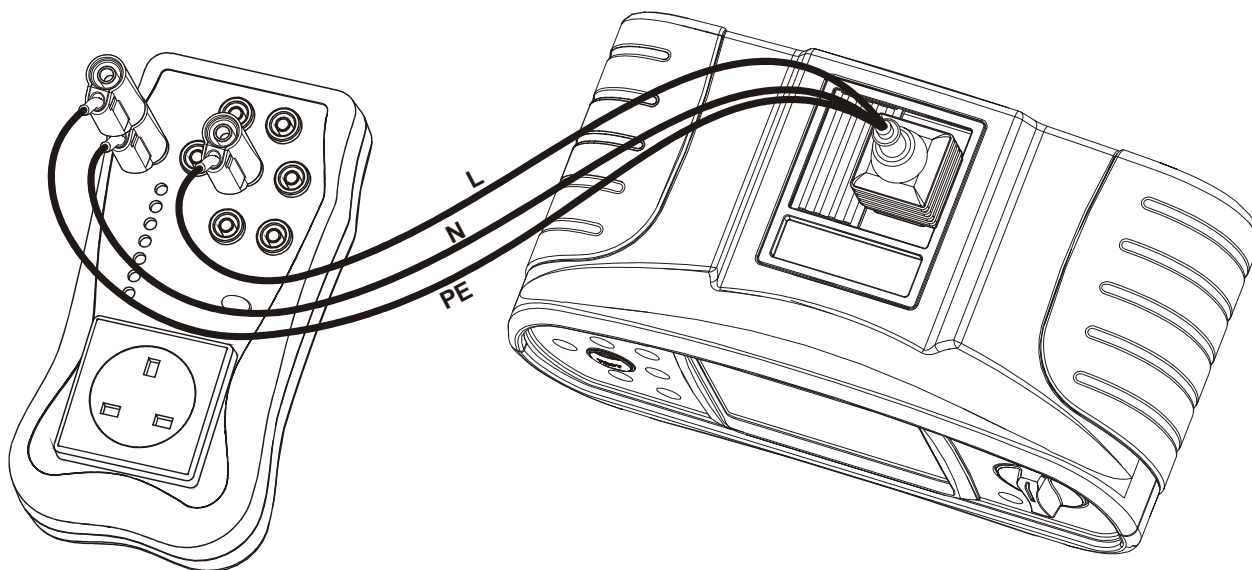

Figure 4.4: Performing low resistance calibration using universal test cable

Step	Action
1	<ul style="list-style-type: none"> ❑ Switch on the tested instrument and select LowΩ function (± 200 mA measuring current). ❑ Compensate measurement leads resistance (see User manual of your instrument for further instructions).
2	<ul style="list-style-type: none"> ❑ Connect tested instrument into Eurocheck low resistance test sockets with universal test cable, follow connection diagram shown in Figure 4.4.
3	<ul style="list-style-type: none"> ❑ It is not necessary to power on Eurocheck when performing insulation resistance calibration ❑ Observe any warnings displayed on the tested instrument. If any is present, remove the causes before proceeding.
4	<ul style="list-style-type: none"> ❑ Perform resistance measurement with the tested instrument. ❑ Write down measurement result for documentation purposes.
5	<ul style="list-style-type: none"> ❑ If measured resistance deviates significantly from reference value, it is very likely the tested instrument is damaged. Send it to your distributor or manufacturer for repair and/or readjustment.
6	<ul style="list-style-type: none"> ❑ Repeat steps 4 and 5 with other reference resistance values.
7	<ul style="list-style-type: none"> ❑ Select continuity function and repeat steps 4 – 6. ❑ Compensation of test leads, performed in LowΩ function, usually applies also for continuity measurement.

Notes:

- ❑ Most Metrel installation test instruments use L and N measuring leads of universal test cable to perform low resistance measurements. However, there are exceptions to this rule like MI 3101 – EurotestAT, which uses N and PE leads.
- ❑ When calibrating Low Ω function make sure that R+ and R- values are also close to reference value! If this is not the case, check measurement cable, or use universal multimeter to measure reference resistors (make sure to reverse polarity). Contact your local distributor or manufacturer for further information.

4.12 Voltage and frequency calibration

Eurocheck offers a.c. voltage source of 50 V (at 230 V mains voltage). This source can be used for voltage and frequency calibration. It is possible (and recommended) to include second value into your calibration procedure – 0 V (short-circuited test leads, not open). Frequency is equal to mains and is usually very close to 50 Hz or 60 Hz.

Most Metrel installation test instruments measure all three line voltages: U_{L-N} , U_{L-PE} and U_{N-PE} . Newer models offer special function where all three voltages can be monitored at the same time. Older models require that separate measurements of all three voltages are performed in different functions (like $R_{LINE} - U_{L-N}$, $R_{LOOP} - U_{L-PE}$ and $R_{N-PE} - U_{N-PE}$). In some models it is possible to use phase rotation function to measure all voltages at the same time. Refer to the User manual of your instrument for more information. However, only one voltage can be calibrated at a time, since Eurocheck offers only 2-lead connection. Leave the unused lead disconnected.

Voltage and frequency measurement calibration can be performed with universal test cable or tip commander. Only universal test cable makes possible calibration of all 3 line voltages. Make sure to follow connection instructions for the tested instrument. Generic connection diagram is shown in Figure 4.5.

Step	Action
1	<ul style="list-style-type: none"> ❑ Connect tested instrument into Eurocheck voltage test sockets using universal test cable, follow connection diagram shown in Figure 4.5; start with L and N leads (U_{L-N} calibration).
2	<ul style="list-style-type: none"> ❑ Switch on the tested instrument and select appropriate voltage measurement function. ❑ Start voltage measurement manually if necessary.
3	<ul style="list-style-type: none"> ❑ Connect Eurocheck into mains wall socket and enable its output. ❑ Observe any warnings displayed on the tested instrument and Eurocheck. ❑ If Eurocheck signals incorrect L and N polarity, reverse connection.
4	<ul style="list-style-type: none"> ❑ Perform voltage and frequency measurement with the tested instrument. ❑ Write down measurement result for documentation purposes.
5	<ul style="list-style-type: none"> ❑ If measured voltage or frequency deviates significantly from reference values, it is very likely the tested instrument is damaged. Send it to your distributor or manufacturer for repair and/or readjustment.
6	<ul style="list-style-type: none"> ❑ Connect another pair of measurement leads to voltage source (L and PE, N and PE) and repeat steps 4 -5.

Notes:

- ❑ Stability of reference voltage depends on mains voltage fluctuations. Use stabile reference a.c. source with 230 V output if better accuracy is necessary. Alternatively measure reference voltage with universal DMM simultaneously (accuracy class 1 % or better).
- ❑ Calibration value represents safe a.c. voltage limit as defined in European LVD directive and is often used as a safe contact voltage limit when testing RCDs.
- ❑ When calibrating 3-voltage measurement system unused voltmeters may show irregular results (this is hardware dependent and presents no problem).
- ❑ When using 230 V source the reference voltage is 47.9 V.

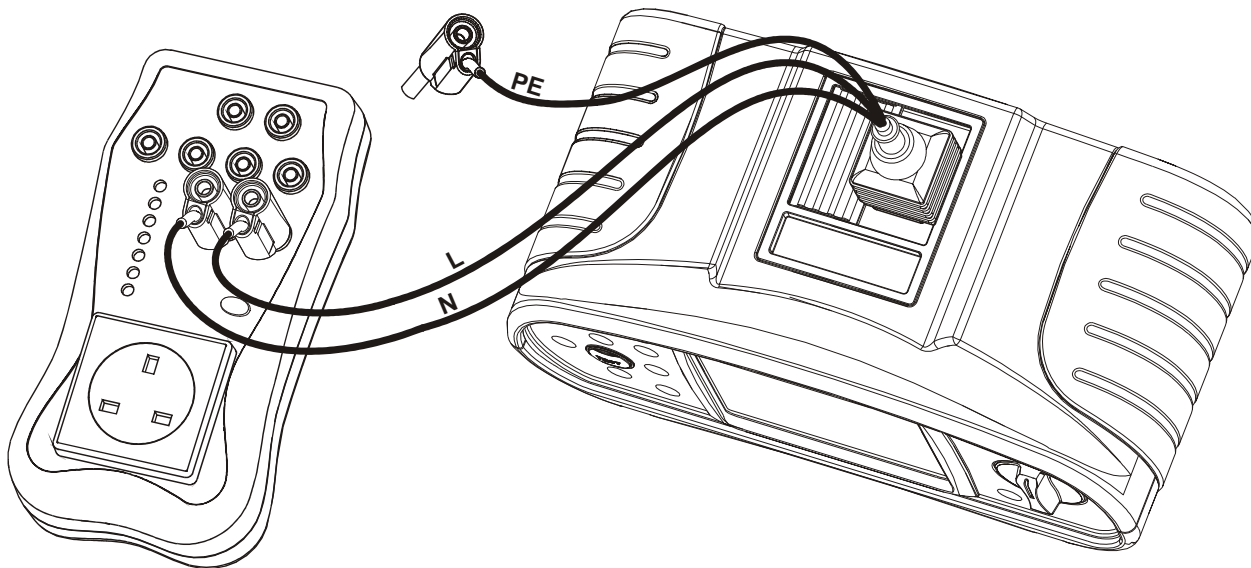

Figure 4.5: Performing voltage and frequency calibration using universal test cable

4.13 Continuity and insulation of measurement leads verification

Continuity of measurement leads

Continuity of universal test cable measurement leads could be verified by voltage calibration between all 3 installation wires (between L and N, L and PE, N and PE). Refer to chapter 4.12 for more information. If the tested instrument measures voltage of around 0 V, at least one of connected leads is broken. By connecting different measurement lead pairs it is possible to determine which one is broken.

Complete verification can be performed with universal test cable only. Other types of measuring cables (plug cable, plug commander and tip commander) can be verified indirectly. First verify universal test cable using procedure for voltage and frequency calibration (see chapter 4.12). Measure voltages between all measurement lead pairs. If all results pass, perform any of calibrations using different Eurocheck sockets and universal test cable. At last perform these calibrations with the other type of cable and compare the results. If they're the same or close to each other, the other cable is acceptable as well.

Notes:

- ❑ Suggested calibrations for verifying continuity of plug cable and plug commander are fault loop (verification of L and PE) and line impedance (verification of L and N).
- ❑ Suggested calibration for verifying continuity of tip commander is low resistance measurement.
- ❑ For quick continuity verification of L and N wires of universal test cable perform low resistance calibration with any reference value (see chapter 4.11).

Insulation of measurement leads

Insulation of measurement leads may deteriorate over time. This can cause measurement and/or safety related problems. If insulation material leaks current measured results will be wrong. Also in such case there is a risk of electric shock when the user touches deteriorated part of insulation.

Eurocheck is not needed to perform this test.

Step	Action
1	<input type="checkbox"/> Switch on the tested instrument and select insulation measurement with 1000 V test voltage (highest available).
2	<input type="checkbox"/> Connect universal test cable to the instrument. Make sure that all measurement leads are in direct connection to each other over the whole length. <input type="checkbox"/> Leave all leads open.
3	<input type="checkbox"/> Start insulation measurement. The instrument must signal over-range measurement result.
4	<input type="checkbox"/> If the instrument measures lower-than-maximum insulation, stop using this measurement cable immediately.

Note:

- It is possible to verify other types of measurement cables as well. Just connect them to the instrument and perform insulation measurement as described above.

4.14 PE test terminal operation verification

Warning:

-  This test uses voltages that are hazardous live. Only adequately trained personnel may perform this test. Ensure that disconnected lead is not exposed.

Verification can be performed with universal test cable only.

Step	Action
1	<input type="checkbox"/> Connect tested instrument into Eurocheck RCD/Fault loop output using universal test cable (use test tips). <input type="checkbox"/> Connect only PE and N leads into L and N sockets respectively.
2	<input type="checkbox"/> Switch on the tested instrument and select fault loop impedance, line impedance or RCD function.
3	<input type="checkbox"/> Connect Eurocheck into mains wall socket and enable RCD/Fault loop output. <input type="checkbox"/> If Eurocheck signals incorrect L and N polarity, reverse connection.
4	<input type="checkbox"/> Touch PE terminal on the tested terminal with your finger – the instrument must signal dangerous line situation. <input type="checkbox"/> Write down test result for documentation purposes.
5	<input type="checkbox"/> If test fails the tested instrument is damaged. Send it immediately to your distributor or manufacturer for repair.

5 Technical specifications

5.1 General

Power supply voltage.....	230 V a.c. (207 V/255 V), 50 Hz/60 Hz
Protection classification	double insulation
Pollution degree.....	2
Protection degree	IP 40
Overvoltage category.....	CAT II 300 V
Power consumption	5 VA

Dimensions (w × h × d)	103 mm × 61 mm × 205 mm
Weight	780 g

Reference conditions

Reference temperature range.....	18 °C ÷ 28 °C
Reference humidity range.....	40 %RH ÷ 70 %RH

Operation conditions

Working temperature range	10 °C ÷ 40 °C
Maximum relative humidity	95 %RH (10 °C ÷ 40 °C), non-condensing

Storage conditions

Temperature range.....	0 °C ÷ +50 °C
Maximum relative humidity	90 %RH (0 °C ÷ +40 °C) 80 %RH (+40 °C ÷ +50 °C)

5.2 Calibration references

Accuracies apply for 1 year in reference conditions.

Insulation resistance

Reference value (MΩ)	Accuracy
2	±1 %
50	

 Maximum test voltage: 1500 V d.c., 1200 V d.c. continuously
In case the calibrator gets moistened the results could be impaired. It is recommended to dry the calibrator for at least 24 hours.

Low resistance

Reference value (Ω)	Accuracy
0.5	±2 %
5	
15	

 Maximum test current: 220 mA d.c.

Voltage and frequency

Reference value	Accuracy
50.0 V @ 230 V a.c.	± (5 % + accuracy of mains voltage)

Short-circuit current: <6 mA.

Nominal output resistance: 25 kΩ.

Specified accuracy is valid only if Eurocheck output is enabled.

Fault loop impedance, trip-lock impedance, line impedance

Reference value (Ω)*	Accuracy
1.2 (LOOP+1 Ω)	±0.2 Ω
11.0 (LOOP+11 Ω)	±0.5 Ω

* This value is added to the actual loop/line impedance. Mains voltage fluctuations affect accuracy of the reference.

 Loading at 230 V a.c.: max. 3 minutes, 25 % duty ratio.

RCD trip-out time simulation and IΔn current measurement

IΔn reference value	Accuracy
30 mA	±1 %
Trip-out time reference value	Accuracy
50 ms	±2 ms
CURRENT LO indication	Accuracy
28 mA	±1 mA
CURRENT HI indication	Accuracy
35 mA	±1 mA

Automatic reset after 3 seconds.

Automatic mains polarity verification

Test is performed in 2 seconds after connection of Eurocheck to mains socket.

Note about reference values

Instead of relying on accuracy specifications given in this chapter, it is possible to use calibrated reference values noted in Eurocheck Production validation certificate. They express lower uncertainty, thus enabling better evaluation of tested instrument.

Note about EN and IEC standards

Text of this manual contains references to European standards. All standards of EN 6xxxx (e.g. EN 61010) series are equivalent to IEC standards with the same number (e.g. IEC 61010) and differ only in amended parts required by European harmonization procedure.